

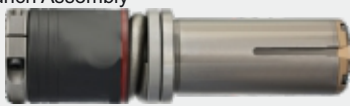

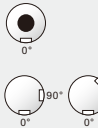



Product		Product Overview
Punch Assembly 	 <p>Single Groove(0°) Double Grooves (0°, 90°)(0°, 135°)</p>	<ul style="list-style-type: none"> <li>• Thinner blades resulting from narrower punches may compromise rigidity.</li> <li>• Traditional stripper plates often leave larger gaps, exposing blades to vulnerability.</li> <li>• Our's Fully Guided Solution eliminates the risk of punch breakage, bending, and die damage.</li> <li>• We only recommend thin material applications.</li> </ul>
Fully Guided Punch 		<ul style="list-style-type: none"> <li>• Enhance structure with better rigidity and less deformation on punch.</li> <li>• Interchangeable: can be installed in others brands punch head assemblies.</li> <li>• Using HRC 63 High-Speed Steel for exceptional durability in high-stress environments.</li> <li>• TiCN coating available upon request for additional protection.</li> </ul>
Fully Guided Guide  <p>Stripper Plate</p>		<ul style="list-style-type: none"> <li>• Close-stripper-to-punch configurations provide robust support for narrow punch blades, extending tool life by at least threefold compared to unguided setups.</li> <li>• Guides treated with nitriding process to enhance compressive, wear, and corrosion resistance.</li> </ul>
Punch Head Assembly 		<ul style="list-style-type: none"> <li>• Our's patent, QuickAdjust , allowing at least twice less amount of time to adjust punch length.</li> </ul>
Die 		<ul style="list-style-type: none"> <li>• Standard: Slugfree.</li> <li>• Options: Slughugger, Vacuum.</li> <li>• After grinding, a die shim is required to maintain a consistent height of 30mm.</li> <li>• We offer 0.4mm [0.0157"] / 0.8mm [0.0315"] / 1.2mm [0.0472"] die shims, 10pcs/pack.</li> </ul>



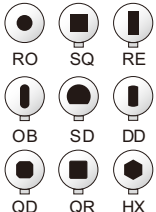

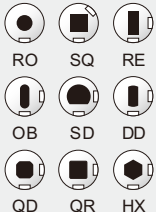

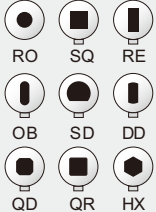
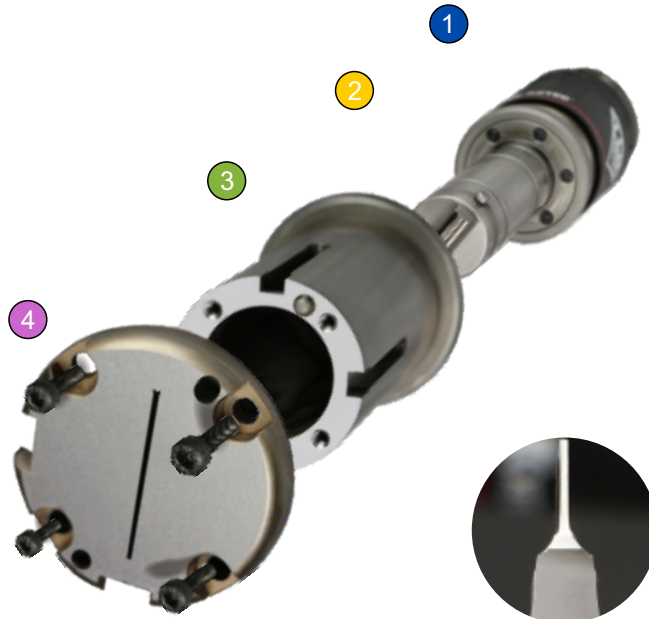



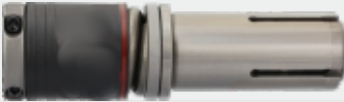













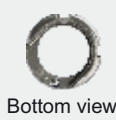









B STATION  
T85 / FULLY GUIDED

**Description**





- 1 Punch head assembly
- 2 Punch
- 3 Guide
- 4 Stripper Plate







- RO: Round.
- RE: Rectangle.
- SQ: Square.
- ▬ OB: Oblong.
- DD: Double D.
- SD: Single D.
- QR: Quad R.
- ◆ HX: Hexagon.
- QD: Quad D.







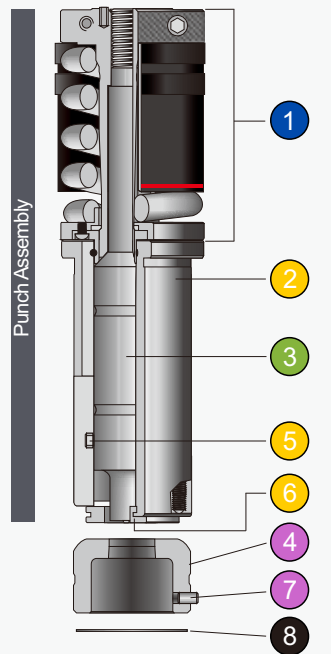

Product		Product Overview
	 Single Groove(0°)  Double Grooves (0°, 90°)(0°, 135°)	<ul style="list-style-type: none"> <li>The universal open guide bushing only requires replacing the stripper plate.</li> </ul>
	 RO  SQ  RE  OB  SD  DD  QD  QR  HX	<ul style="list-style-type: none"> <li>Interchangeable: can be installed in others brands punch head assemblies.</li> <li>Using HRC 63 High-Speed Steel for exceptional durability in high-stress environments.</li> <li>TICN coating available upon request for additional protection.</li> </ul>
   Bottom view	 RO  SQ  RE  OB  SD  DD  QD  QR  HX	<ul style="list-style-type: none"> <li>Guides treated with nitriding process to enhance compressive, wear, and corrosion resistance.</li> </ul>
		<ul style="list-style-type: none"> <li>Our's patent, QuickAdjust™, allowing at least twice less amount of time to adjust punch length.</li> </ul>
	 RO  SQ  RE  OB  SD  DD  QD  QR  HX	<ul style="list-style-type: none"> <li>Standard: Slugfree.</li> <li>Options: Slughugger, Vacuum.</li> <li>After grinding, a die shim is required to maintain a consistent height of 30mm.</li> <li>We offer 0.4mm [0.0157"] / 0.8mm [0.0315"] / 1.2mm [0.0472"] die shims, 10pcs/pack.</li> </ul>







Description

-  Punch head assembly
-  Punch
-  Guide
-  Die
-  Stripper

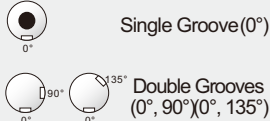
-  Ejector
-  Dowel pin
-  Die shim
-  Punch assembly

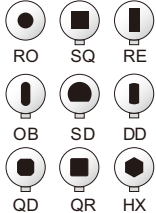

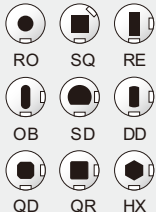
-  RO: Round.
-  RE: Rectangle.
-  SQ: Square.
-  OB: Oblong.
-  DD: Double D.
-  SD: Single D.
-  QR: Quad R.
-  HX: Hexagon.
-  QD: Quad D.

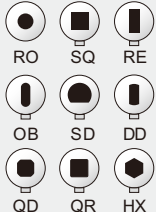
Product		Product Overview
		<ul style="list-style-type: none"> <li>The universal open guide bushing only requires replacing the stripper plate.</li> </ul>
		<ul style="list-style-type: none"> <li>Interchangeable: can be installed in others brands punch head assemblies.</li> <li>Using HRC 63 High-Speed Steel for exceptional durability in high-stress environments.</li> <li>TiCN coating available upon request for additional protection.</li> </ul>
		<ul style="list-style-type: none"> <li>Guides treated with nitriding process to enhance compressive, wear, and corrosion resistance.</li> </ul>
		<ul style="list-style-type: none"> <li>Our's patent, QuickAdjust , allowing at least twice less amount of time to adjust punch length.</li> </ul>
		<ul style="list-style-type: none"> <li>Standard: Slugfree.</li> <li>Options: Slughugger, Vacuum.</li> <li>After grinding, a die shim is required to maintain a consistent height of 30mm.</li> <li>We offer 0.4mm [0.0157"] / 0.8mm [0.0315"] / 1.2mm [0.0472"] die shims, 10pcs/pack.</li> </ul>







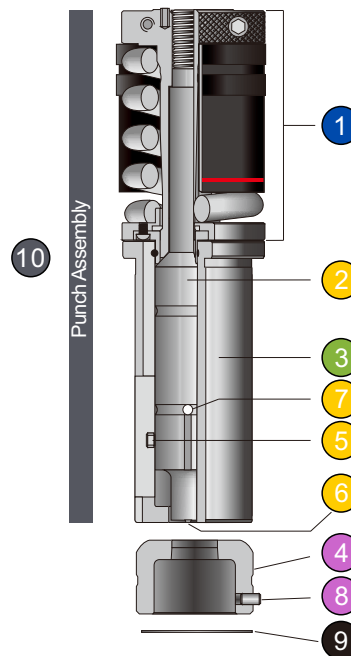

Description

- 1 Punch head assembly
- 2 Punch
- 3 Guide
- 4 Die
- 5 Dowel pin

- 6 Ejector
- 7 ABS hole
- 8 Dowel pin
- 9 Die shim
- 10 Punch assembly

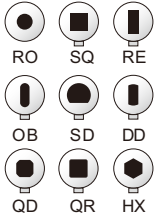

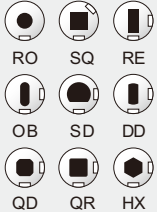
- RO: Round.
- RE: Rectangle.
- SQ: Square.
- ▭ OB: Oblong.
- DD: Double D.
- SD: Single D.
- QR: Quad R.
- ◆ HX: Hexagon.
- QD: Quad D.

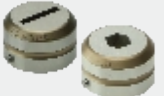
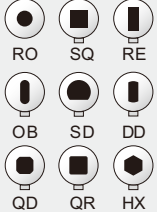
Product	Product Overview	
<p>Punch Assembly</p> 	 Single Groove(0°)  Double Grooves (0°, 90°) (0°, 135°)	<ul style="list-style-type: none"> <li>• Our's fully guided solution eliminates the risk of punch breakage, bending, and die damage.</li> <li>• We only recommend thin material applications.</li> <li>• ABS: oil mist lubrication, anti-scratch, anti-adhesion, longer punch life.</li> </ul>
<p>Fully Guide Punch ABS</p> 		<ul style="list-style-type: none"> <li>• Enhance structure with better rigidity and less deformation on punch.</li> <li>• Using HRC 63 High-Speed Steel for exceptional durability in high-stress environments.</li> <li>• TiCN coating available upon request for additional protection.</li> </ul>
<p>Fully Guided Guide ABS</p>  <p>Stripper Plate ABS</p> 		<ul style="list-style-type: none"> <li>• Guides treated with nitriding process to enhance compressive, wear, and corrosion resistance.</li> </ul>
<p>Punch Head Assembly</p> 		<ul style="list-style-type: none"> <li>• Our's patent, QuickAdjust™, allowing at least twice less amount of time to adjust punch length.</li> </ul>
<p>Die</p> 		<ul style="list-style-type: none"> <li>• Standard: Slugfree.</li> <li>• Options: Slughugger, Vacuum.</li> <li>• After grinding, a die shim is required to maintain a consistent height of 30mm.</li> <li>• We offer 0.4mm [0.0157"] / 0.8mm [0.0315"] / 1.2mm [0.0472"] die shims, 10pcs/pack.</li> </ul>

Description





- 1 Punch head assembly
- 2 Punch
- 3 Guide
- 4 Punch assembly



1 2 3 4

- RO: Round.
- RE: Rectangle.
- SQ: Square.
- ▭ OB: Oblong.
- ▭ DD: Double D.
- SD: Single D.
- QR: Quad R.
- ◆ HX: Hexagon.
- QD: Quad D.

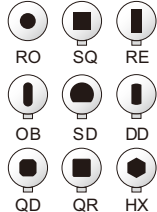
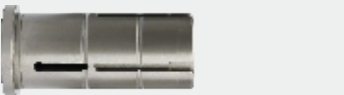
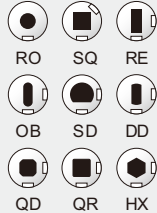

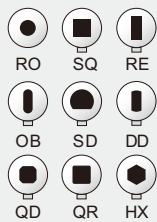
Product		Product Overview
		<ul style="list-style-type: none"> <li>The universal open guide bushing only requires replacing the stripper plate.</li> </ul>
		<ul style="list-style-type: none"> <li>Interchangeable: can be installed in others brands punch head assemblies.</li> <li>Using HRC 63 High-Speed Steel for exceptional durability in high-stress environments.</li> <li>TiCN coating available upon request for additional protection.</li> </ul>
		<ul style="list-style-type: none"> <li>Guides treated with nitriding process to enhance compressive, wear, and corrosion resistance.</li> </ul>
		<ul style="list-style-type: none"> <li>Our's patent, QuickAdjust™, allowing at least twice less amount of time to adjust punch length.</li> </ul>
		<ul style="list-style-type: none"> <li>Standard: Slugfree.</li> <li>Options: Slughugger, Vacuum.</li> <li>After grinding, a die shim is required to maintain a consistent height of 30mm.</li> <li>We offer 0.4mm [0.0157"] / 0.8mm [0.0315"] / 1.2mm [0.0472"] die shims, 10pcs/pack.</li> </ul>



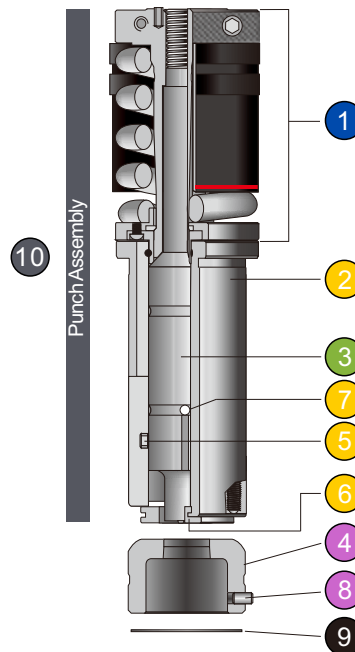

Description

- 1 Punch head assembly
- 2 Punch
- 3 Guide
- 4 Die
- 5 Stripper

- 6 Ejector
- 7 Dowel pin
- 8 Dowel pin
- 9 Die shim
- 10 Punch assembly

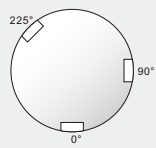

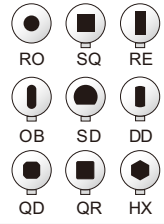
- RO: Round.
- RE: Rectangle.
- SQ: Square.
- ▭ OB: Oblong.
- ▭ DD: Double D.
- SD: Single D.
- QR: Quad R.
- ⬠ HX: Hexagon.
- QD: Quad D.

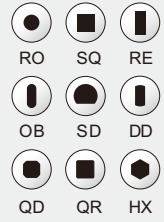
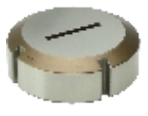
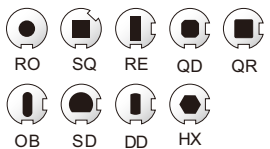
Product	Product Overview	
Punch Assembly 	Triple Grooves (0°, 90°, 225°) 	<ul style="list-style-type: none"> <li>• Our's T85 series stands out as one of our top-selling products, offering enhanced versatility and durability compared to the E85 series.</li> <li>• To adjust length, press down on the quick-adjust button, rotate the punch head clockwise or counterclockwise to adjust punch length.</li> </ul>
Punch 		<ul style="list-style-type: none"> <li>• Interchangeable: can be installed in other brands guide assemblies.</li> <li>• Extended grind life of 8mm, rooftop shear available upon request.</li> <li>• TiCN coating available upon request for additional protection.</li> </ul>
Stripper Plate 		<ul style="list-style-type: none"> <li>• 85 Stripper</li> </ul>
Die 		<ul style="list-style-type: none"> <li>• Standard: Slugfree.</li> <li>• Options: Slughugger, Vacuum.</li> <li>• After grinding, a die shim is required to maintain a consistent height of 30mm.</li> <li>• We offer 0.4mm [0.0157"] / 0.8mm [0.0315"] / 1.2mm [0.0472"] die shims, 5pcs/pack.</li> </ul>







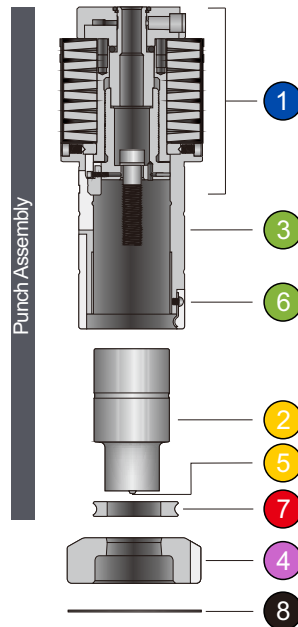

Description

- 1 Punch head assembly
- 2 Punch
- 3 Guide
- 4 Die
- 5 Ejector

- 6 Stripper screw & clip
- 7 Stripper plate
- 8 Die shim
- 9 Punch assembly

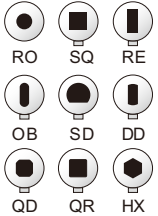

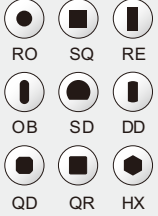
- RO: Round.
- RE: Rectangle.
- SQ: Square.
- ▬ OB: Oblong.
- ▬ DD: Double D.
- SD: Single D.
- QR: Quad R.
- ⬠ HX: Hexagon.
- QD: Quad D.

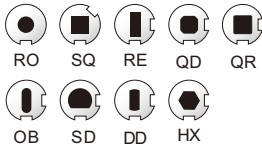
Product		Product Overview
Punch Assembly 	 <p>Structure inside the canister</p>  <p>Triple Grooves (0°, 90°, 225°)</p>	<ul style="list-style-type: none"> <li>• Eliminate or reduce the sheet marks.</li> <li>• Reduce noise, extend spring life time.</li> <li>• Adjust the punch force by change different color springs.</li> </ul>
Punch 		<ul style="list-style-type: none"> <li>• Interchangeable: can be installed in other brands guide assemblies.</li> <li>• Extended grind life of 8mm, rooftop shear available upon request.</li> <li>• TiCN coating available upon request for additional protection.</li> </ul>
Stripper Plate 		<ul style="list-style-type: none"> <li>• 85 Stripper</li> </ul>
Die 		<ul style="list-style-type: none"> <li>• Standard: Slugfree.</li> <li>• Options: Slughugger, Vacuum.</li> <li>• After grinding, a die shim is required to maintain a consistent height of 30mm.</li> <li>• We offer 0.4mm [0.0157"] / 0.8mm [0.0315"] / 1.2mm [0.0472"] die shims, 5pcs/pack.</li> </ul>

SPL Light Duty Family

- A Station
- B Station
- C Station
- D Station
- E Station



Product	Product Overview	
<p>Punch Assembly</p> 	<p>Double Grooves (0°, 90°)</p> 	<ul style="list-style-type: none"> <li>• Thinner blades resulting from narrower punches may compromise rigidity.</li> <li>• Traditional stripper plates often leave larger gaps, exposing blades to vulnerability.</li> <li>• Our's Fully Guided Solution eliminates the risk of punch breakage, bending, and die damage.</li> <li>• We only recommend thin material applications.</li> </ul>
<p>Punch</p> 		<ul style="list-style-type: none"> <li>• Enhance structure with better rigidity and less deformation on punch.</li> <li>• Interchangeable: can be installed in others brands guide assemblies.</li> <li>• Using HRC 63 High-Speed Steel for exceptional durability in high-stress environments.</li> <li>• TiCN coating &amp; rooftop shear are available upon request for additional protection.</li> </ul>
<p>Stripper Plate</p> 		<ul style="list-style-type: none"> <li>• Close-stripper-to-punch configurations provide robust support for narrow punch blades, extending tool life by at least threefold compared to unguided setups.</li> </ul>
<p>Die</p> 		<ul style="list-style-type: none"> <li>• Standard: Slugfree.</li> <li>• Options: Slughugger, Vacuum.</li> <li>• After grinding, a die shim is required to maintain a consistent height of 30mm.</li> <li>• We offer 0.4mm [0.0157"] / 0.8mm [0.0315"] / 1.2mm [0.0472"] die shims, 5pcs/pack.</li> </ul>

Description

1 Punch head assembly

2 Punch



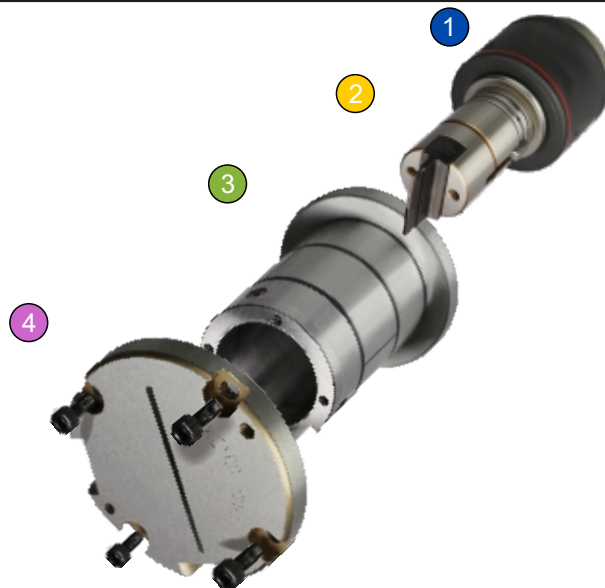

3 Guide

4 Stripper Plate

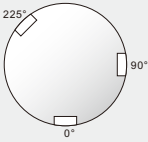

- RO: Round.
- RE: Rectangle.
- SQ: Square.
- ▬ OB: Oblong.
- ▬ DD: Double D.
- SD: Single D.
- QR: Quad R.
- ◆ HX: Hexagon.
- QD: Quad D.

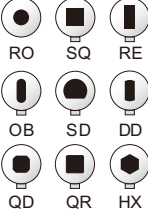
C STATION T85 FULLY GUIDED

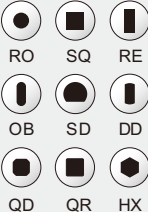
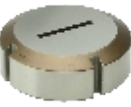
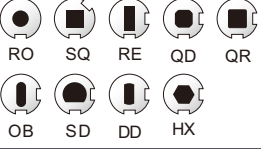
Product		Product Overview
<p>Punch Assembly</p> 	<p>Triple Grooves (0°, 90°, 225°)</p> 	<ul style="list-style-type: none"> <li>• ABS: Air Blow System, oil mist lubrication, anti-scratch, anti-adhesion, longer punch life.</li> </ul>
<p>Punch ABS</p> 		<ul style="list-style-type: none"> <li>• Interchangeable: can be installed in other brands guide assemblies.</li> <li>• Using HRC 63 High-Speed Steel for exceptional durability in high-stress environments.</li> <li>• TiCN coating &amp; rooftop shear are available upon request for additional protection.</li> </ul>
<p>Stripper Plate ABS</p> 		<ul style="list-style-type: none"> <li>• 85 ABS Stripper</li> </ul>
<p>Die</p> 		<ul style="list-style-type: none"> <li>• Standard: Slugfree.</li> <li>• Options: Slughugger, Vacuum.</li> <li>• After grinding, a die shim is required to maintain a consistent height of 30mm.</li> <li>• We offer 0.4mm [0.0157"] / 0.8mm [0.0315"] / 1.2mm [0.0472"] die shims, 5pcs/pack.</li> </ul>







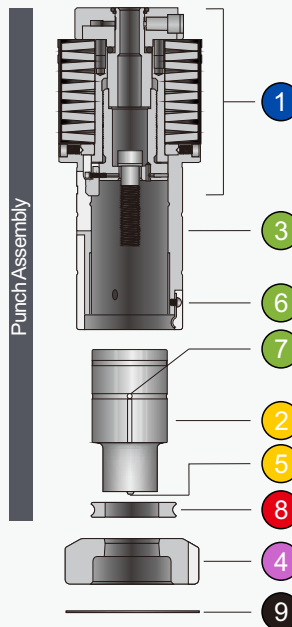

Description

- 1 Punch head assembly
- 2 Punch ABS
- 3 Guide
- 4 Die
- 5 Ejector

- 6 Stripper screw & clip
- 7 ABS hole
- 8 Stripper plate ABS
- 9 Die shim
- 10 Punch assembly





- RO: Round.
- RE: Rectangle.
- SQ: Square.
- ▭ OB: Oblong.
- ▭ DD: Double D.
- SD: Single D.
- QR: Quad R.
- ◆ HX: Hexagon.
- QD: Quad D.

Product		Product Overview
Slitting Punch (Type 19)  	T85 + Slitting Punch T85 Light Duty + Slitting Punch T85 Fully Guided + Slitting Punch E85 + Slitting Punch	<ul style="list-style-type: none"> <li>Based on the 85 punch holder, interchangeable punch sizes are available</li> <li>It is suitable for various rectangular or oblong cutting tools.</li> </ul>
Clusters (Punch, Die, Stripper Plate)  	T85 Cluster T85 ABS Cluster T85 Fully Guided Cluster E85 Cluster	<ul style="list-style-type: none"> <li>Cluster is one of the commonly and widely used methods in sheet metal processing.</li> <li>The 85 series is equipped with a cluster slitting punch for customers to choose.</li> <li>Customers only need to provide the sheet metal drawing, thickness, machine model information.</li> </ul>
Blank Die  		<ul style="list-style-type: none"> <li>Mostly use in forming tools, such as lots of form down centerpoint, form down stamping logo / letter...</li> </ul>
Roller Ball Die  		<ul style="list-style-type: none"> <li>The function of the roller ball die is for scratch-resistant sheets.</li> </ul>
Brush Die  		<ul style="list-style-type: none"> <li>The function of the roller ball die is for scratch-resistant sheets.</li> </ul>
90 Guide  		<ul style="list-style-type: none"> <li>Use for T85 / T85ABS / T85 LIGHT DUTY.</li> </ul>
85 Guide  		<ul style="list-style-type: none"> <li>Only for E85.</li> </ul>
Fully Guided  		<ul style="list-style-type: none"> <li>Only for Fully Guided.</li> </ul>

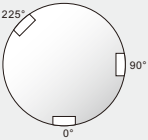

Product	Product Overview	Product Overview
<p>Slitting Punch (Type 16)</p> 	<p>T85 + Slitting Punch                      T85 Light Duty + Slitting Punch                      T85 Fully Guided + Slitting Punch                      E85 + Slitting Punch</p>	<ul style="list-style-type: none"> <li>Based on the 85 punch holder, interchangeable punch sizes are available</li> <li>It is suitable for various rectangular or oblong cutting tools.</li> </ul>
<p>Clusters (Punch, Die, Stripper Plate)</p> 	<p>T85 Cluster                      T85 ABS Cluster                      T85 Fully Guided Cluster                      E85 Cluster</p>	<ul style="list-style-type: none"> <li>Cluster is one of the commonly and widely used methods in sheet metal processing.</li> <li>The 85 series is equipped with a cluster slitting punch for customers to choose.</li> <li>Customers only need to provide the sheet metal drawing, thickness, machine model information.</li> </ul>
<p>Blank Die</p>  <p>Roller Ball Die</p>  <p>Brush Die</p> 	<ul style="list-style-type: none"> <li>Mostly use in forming tools, such as lots of form down centerpoint, form down stamping logo / letter...</li> <li>The function of the roller ball die is for scratch-resistant sheets.</li> <li>The function of the roller ball die is for scratch-resistant sheets.</li> </ul>	
<p>90 Guide</p>  <ul style="list-style-type: none"> <li>Use for T85 / T85 ABS, T85 LIGHT DUTY.</li> </ul>	<p>Close to Clamp</p>  <ul style="list-style-type: none"> <li>Use for T85 CLOSE TO CLAMP, T85 CLOSE TO CLAMP LIGHT DUTY.</li> </ul>	
<p>85 Guide</p>  <ul style="list-style-type: none"> <li>Only use for E85.</li> </ul>	<p>Fully Guided</p>  <ul style="list-style-type: none"> <li>Only use for Fully Guided.</li> </ul>	

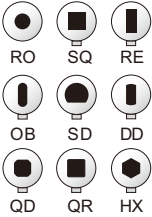
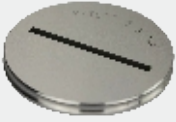
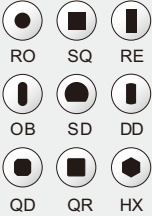
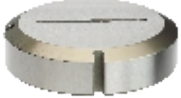
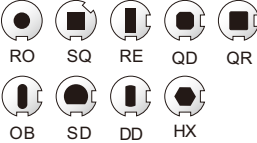
Product		Product Overview
<p>Punch Assembly</p> 	<p>Triple Grooves (0°, 90°, 225°)</p> 	<ul style="list-style-type: none"> <li>• Our's T85 series stands out as one of our top-selling products, offering enhanced versatility and durability compared to the E85 series.</li> <li>• To adjust length, press down on the quick-adjust button, rotate the punch head clockwise or counterclockwise to adjust punch length.</li> </ul>
<p>Standard Punch</p> 		<ul style="list-style-type: none"> <li>• Interchangeable: can be installed in other brands guide assemblies.</li> <li>• Extended grind life of 8mm, rooftop shear available upon request.</li> <li>• TiCN coating available upon request for additional protection.</li> </ul>
<p>Stripper Plate</p> 		<ul style="list-style-type: none"> <li>• 85 Stripper</li> </ul>
<p>Die</p> 		<ul style="list-style-type: none"> <li>• Standard: Slugfree.</li> <li>• Options: Slughugger, Vacuum.</li> <li>• After grinding, a die shim is required to maintain a consistent height of 30mm.</li> <li>• We offer 0.4mm [0.0157"] / 0.8mm [0.0315"] / 1.2mm [0.0472"] die shims, 5pcs/pack.</li> </ul>

Description

- 1 Punch head assembly
- 2 Punch
- 3 Guide
- 4 Die
- 5 Ejector

- 6 Stripper screw & clip
- 7 Stripper plate
- 8 Die shim
- 9 Punch assembly

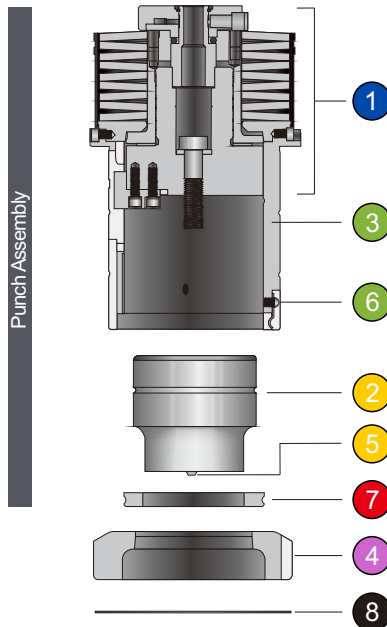

- RO: Round.
- RE: Rectangle.
- SQ: Square.
- ▭ OB: Oblong.
- ▭ DD: Double D.
- SD: Single D.
- QR: Quad R.
- ⬠ HX: Hexagon.
- QD: Quad D.