

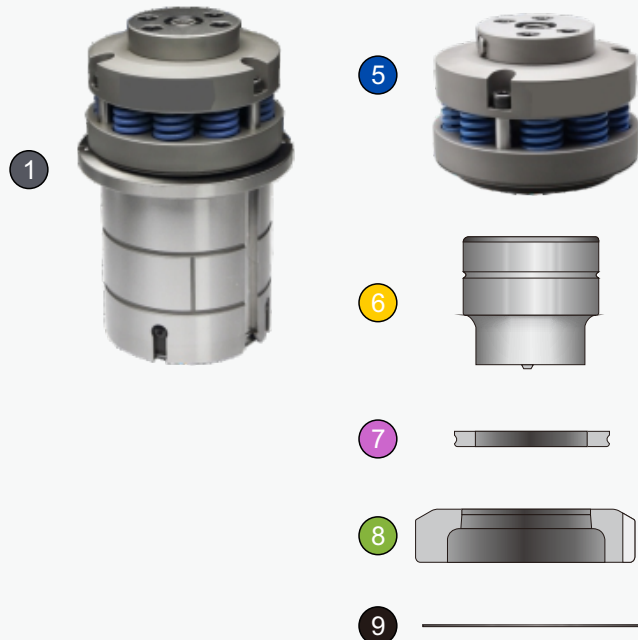

Product		Product Overview
<p>Punch Assembly</p> 	 <p>Structure inside the canister</p>  <p>Triple Grooves (0°, 90°, 225°)</p>	<ul style="list-style-type: none"> • Eliminate or reduce the sheet marks. • Reduce noise, extend spring life time. • Adjust the punch force by change different color springs.
<p>Standard Punch</p> 		<ul style="list-style-type: none"> • Interchangeable: can be installed in other brands guide assemblies. • Extended grind life of 8mm, rooftop shear available upon request. • TiCN coating available upon request for additional protection.
<p>Stripper Plate</p> 		<ul style="list-style-type: none"> • 85 Stripper
<p>Die</p> 		<ul style="list-style-type: none"> • Standard: Slugfree. • Options: Slughugger, Vacuum. • After grinding, a die shim is required to maintain a consistent height of 30mm. • We offer 0.4mm [0.0157"] / 0.8mm [0.0315"] / 1.2mm [0.0472"] die shims, 5pcs/pack.

Description

- 1 Guide assembly
- 2 Blue springs (Light)
- 3 Red springs (Medium)
- 4 Green springs (Heavy)
- 5 Punch head assembly
- 6 Punch
- 7 Stripper plate
- 8 Die
- 9 Die shim



- RO: Round.
- RE: Rectangle.
- SQ: Square.
- ▭ OB: Oblong.
- ▭ DD: Double D.
- SD: Single D.
- QR: Quad R.
- ◆ HX: Hexagon.
- QD: Quad D.



Product	Product Overview	
<p>Punch Assembly</p> 	<p>Double Grooves (0°, 90°)</p> 	<ul style="list-style-type: none"> • Thinner blades resulting from narrower punches may compromise rigidity. • Traditional stripper plates often leave larger gaps, exposing blades to vulnerability. • Our's Fully Guided Solution eliminates the risk of punch breakage, bending, and die damage. • We only recommend thin material applications.
<p>Fully Guided Punch</p> 		<ul style="list-style-type: none"> • Enhance structure with better rigidity and less deformation on punch. • Interchangeable: can be installed in others brands guide assemblies. • Using HRC 63 High-Speed Steel for exceptional durability in high-stress environments. • TiCN coating & rooftop shear are available upon request for additional protection.
<p>Stripper Plate</p> 		<ul style="list-style-type: none"> • Close-stripper-to-punch configurations provide robust support for narrow punch blades, extending tool life by at least threefold compared to unguided setups.
<p>Die</p> 		<ul style="list-style-type: none"> • Standard: Slugfree. • Options: Slughugger, Vacuum. • After grinding, a die shim is required to maintain a consistent height of 30mm. • We offer 0.4mm [0.0157"] / 0.8mm [0.0315"] / 1.2mm [0.0472"] die shims, 5pcs/pack.

Description

- 1 Punch head assembly
- 2 Punch
- 3 Guide
- 4 Stripper Plate

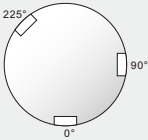

- RO: Round.
- RE: Rectangle.
- SQ: Square.
- ▬ OB: Oblong.
- ▬ DD: Double D.
- SD: Single D.
- QR: Quad R.
- ⬠ HX: Hexagon.
- QD: Quad D.

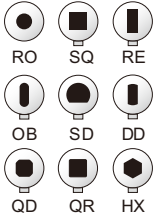
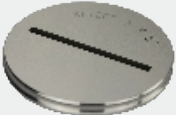
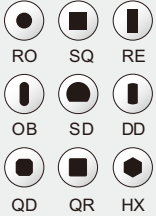
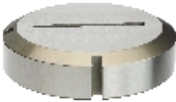
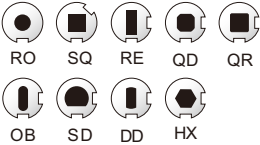
Product		Product Overview
	<p>Triple Grooves (0°, 90°, 225°)</p> 	<ul style="list-style-type: none"> • ABS: Air Blow System, oil mist lubrication, anti-scratch, anti-adhesion, longer punch life.
<p>Standard Punch ABS</p> 		<ul style="list-style-type: none"> • Interchangeable: can be installed in other brands guide assemblies. • Using HRC 63 High-Speed Steel for exceptional durability in high-stress environments. • TiCN coating & rooftop shear are available upon request for additional protection.
<p>Stripper Plate ABS</p> 		<ul style="list-style-type: none"> • 85 ABS Stripper
<p>Die</p> 		<ul style="list-style-type: none"> • Standard: Slugfree. • Options: Slughugger, Vacuum. • After grinding, a die shim is required to maintain a consistent height of 30mm. • We offer 0.4mm [0.0157"] / 0.8mm [0.0315"] / 1.2mm [0.0472"] die shims, 5pcs/pack.

Description

- | | |
|------------------------------|--------------------------------|
| 1 Punch head assembly | 6 Stripper screw & clip |
| 2 Punch ABS | 7 ABS hole |
| 3 Guide | 8 Stripper plate ABS |
| 4 Die | 9 Die shim |
| 5 Ejector | 10 Punch assembly |

Punch Assembly

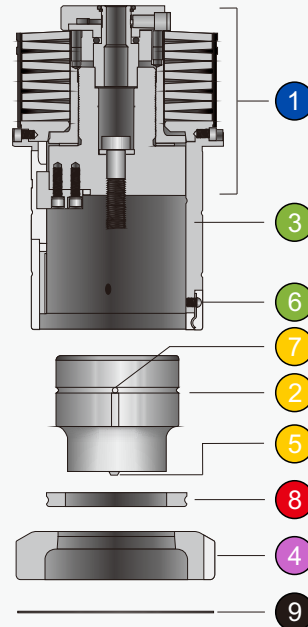

- RO: Round.
- RE: Rectangle.
- SQ: Square.
- ▭ OB: Oblong.
- ▭ DD: Double D.
- SD: Single D.
- QR: Quad R.
- HX: Hexagon.
- QD: Quad D.

Product	Product Overview	
<p>Punch Assembly</p> 	<p>Double Grooves (0°, 90°)</p> 	<ul style="list-style-type: none"> Parting and slitting are common practices in sheet metal fabrication. Whether you are parting nested parts or straightening the edge of the sheet, you need a Close-to-clamp tool specifically to maximize your productivity for those applications.
<p>Punch Blade</p> 		<ul style="list-style-type: none"> Using HRC 63 High-Speed Steel for exceptional durability in high-stress environments. TiCN coating and rooftop shear are available upon request for additional protection. Common sizes: RE5*100 OBØ6*100
<p>Stripper Plate</p> 		<ul style="list-style-type: none"> Close-to-clamp stripper maximizes sheet use
<p>Die (Close to Clamp)</p> 		<ul style="list-style-type: none"> Standard: Slugfree. Options: Slughugger, Vacuum. After grinding, a die shim is required to maintain a consistent height of 30mm. We offer 0.4mm [0.0157"] / 0.8mm [0.0315"] / 1.2mm [0.0472"] die shims, 5pcs/pack.

Description

1 Guide assembly

2 Punch

3 Die





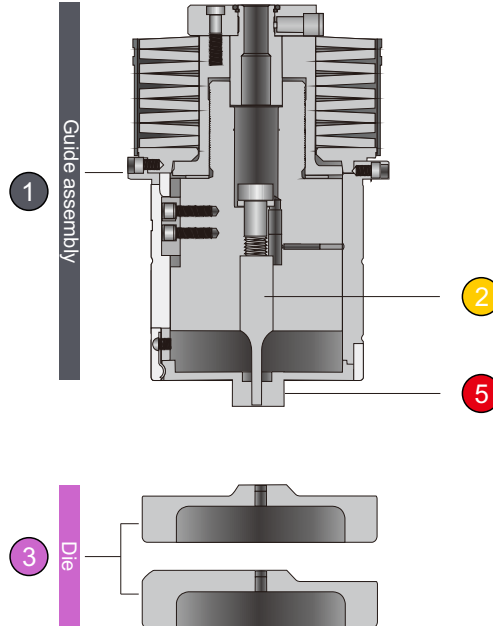



4 Guide

5 Stripper Plate

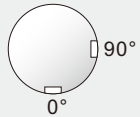

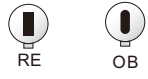
- RO: Round.
- RE: Rectangle.
- SQ: Square.
- OB: Oblong.
- DD: Double D.
- SD: Single D.
- QR: Quad R.
- HX: Hexagon.
- QD: Quad D.

D STATION T85 / CLOSE TO CLAMP



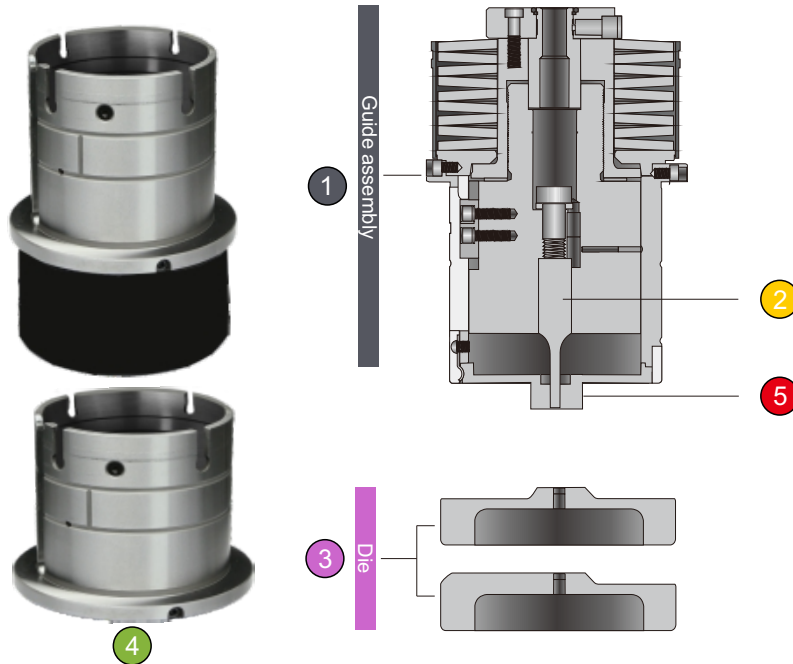

Product		Product Overview
<p>Punch Assembly</p> 	 <p>Structure inside the canister</p>  <p>Double Grooves (0°, 90°)</p>	<ul style="list-style-type: none"> Parting and slitting are common practices in sheet metal fabrication. Whether you are parting nested parts or straightening the edge of the sheet, you need a Close-to-clamp tool specifically to maximize your productivity for those applications.
<p>Punch Blade</p> 	 <p>RE OB</p>	<ul style="list-style-type: none"> Using HRC 63 High-Speed Steel for exceptional durability in high-stress environments. TICN coating and rooftop shear are available upon request for additional protection. Common sizes: RE5*80 OBØ6*80
<p>Stripper Plate</p> 	 <p>RE OB</p>	<ul style="list-style-type: none"> Close-to-clamp stripper maximizes sheet use
<p>Die (Close to Clamp)</p> 	 <p>RE OB</p>	<ul style="list-style-type: none"> Standard: Slugfree. Options: Slughugger, Vacuum. After grinding, a die shim is required to maintain a consistent height of 30mm. We offer 0.4mm [0.0157"] / 0.8mm [0.0315"] / 1.2mm [0.0472"] die shims, 5pcs/pack.

Description

- 1 Guide assembly
- 2 Punch
- 3 Die
- 4 Guide
- 5 Stripper Plate

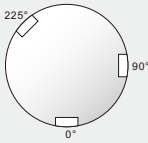
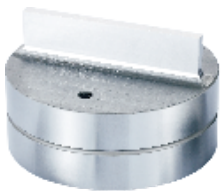
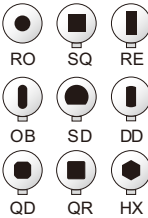

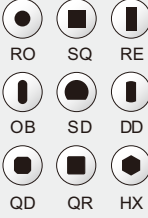
- RO: Round.
- RE: Rectangle.
- SQ: Square.
- ▭ OB: Oblong.
- DD: Double D.
- SD: Single D.
- QR: Quad R.
- ◆ HX: Hexagon.
- QD: Quad D.

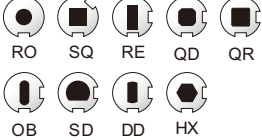
Product		Product Overview
Punch Assembly 		<ul style="list-style-type: none"> • Our's T85 series stands out as one of our top-selling products, offering enhanced versatility and durability compared to the E85 series. • To adjust length, press down on the quick-adjust button, rotate the punch head clockwise or counterclockwise to adjust punch length.
Punch 		<ul style="list-style-type: none"> • Interchangeable: can be installed in other brands guide assemblies. • Extended grind life of 8mm, rooftop shear available upon request. • TiCN coating available upon request for additional protection.
Stripper Plate 		<ul style="list-style-type: none"> • 85 Stripper
Die 		<ul style="list-style-type: none"> • Standard: Slugfree. • Options: Slughugger, Vacuum. • After grinding, a die shim is required to maintain a consistent height of 30mm. • We offer 0.4mm [0.0157"] / 0.8mm [0.0315"] / 1.2mm [0.0472"] die shims, 5pcs/pack.

Description

1 Guide assembly

2 Punch ABS

3 Die

4 Stripper Plate ABS

5 Die shim

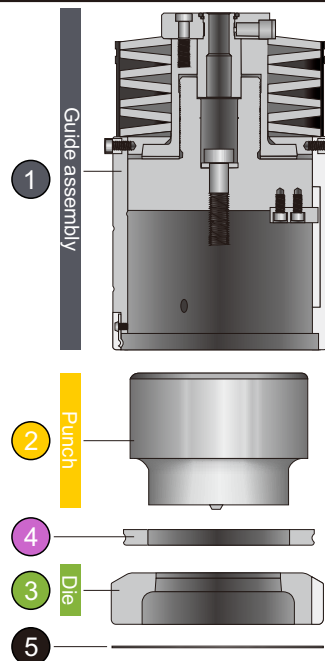

- RO: Round.
- RE: Rectangle.
- SQ: Square.
- ▬ OB: Oblong.
- ▬ DD: Double D.
- SD: Single D.
- QR: Quad R.
- ◆ HX: Hexagon.
- QD: Quad D.

Product		Product Overview
<p>Punch Assembly</p> 	 <p>Structure inside the canister</p>  <p>Triple Grooves (0°, 90°, 225°)</p>	<ul style="list-style-type: none"> • Eliminate or reduce the sheet marks. • Reduce noise, extend spring life time. • Adjust the punch force by change different color springs.
<p>Punch</p> 		<ul style="list-style-type: none"> • Interchangeable: can be installed in other brands guide assemblies. • Extended grind life of 8mm, rooftop shear available upon request. • TiCN coating available upon request for additional protection.
<p>Stripper Plate</p> 		<ul style="list-style-type: none"> • 85 Stripper
<p>Die</p> 		<ul style="list-style-type: none"> • Standard: Slugfree. • Options: Slughugger, Vacuum. • After grinding, a die shim is required to maintain a consistent height of 30mm. • We offer 0.4mm [0.0157"] / 0.8mm [0.0315"] / 1.2mm [0.0472"] die shims, 5pcs/pack.

Description

- 1 Guide assembly
- 2 Blue springs (Light)
- 3 Red springs (Medium)
- 4 Green springs (Heavy)
- 5 Punch head assembly
- 6 Punch
- 7 Stripper plate
- 8 Die
- 9 Die shim



- RO: Round.
- RE: Rectangle.
- SQ: Square.
- ▭ OB: Oblong.
- ▭ DD: Double D.
- SD: Single D.
- QR: Quad R.
- ◆ HX: Hexagon.
- QD: Quad D.

Product		Product Overview
Punch Assembly 	Double Grooves (0°, 90°) 	<ul style="list-style-type: none"> • Thinner blades resulting from narrower punches may compromise rigidity. • Traditional stripper plates often leave larger gaps, exposing blades to vulnerability. • Our's Fully Guided Solution eliminates the risk of punch breakage, bending, and die damage. • We only recommend thin material applications.
Punch 		<ul style="list-style-type: none"> • Enhance structure with better rigidity and less deformation on punch. • Interchangeable: can be installed in others brands guide assemblies. • Using HRC 63 High-Speed Steel for exceptional durability in high-stress environments. • TiCN coating & rooftop shear are available upon request for additional protection.
Stripper Plate 		<ul style="list-style-type: none"> • Close-stripper-to-punch configurations provide robust support for narrow punch blades, extending tool life by at least threefold compared to unguided setups.
Die 		<ul style="list-style-type: none"> • Standard: Slugfree. • Options: Slughugger, Vacuum. • After grinding, a die shim is required to maintain a consistent height of 30mm. • We offer 0.4mm [0.0157"] / 0.8mm [0.0315"] / 1.2mm [0.0472"] die shims, 5pcs/pack.

Description

1



Thick Turret/T85 Fully Guided Punch Assembly/E

2



Thick Turret/T85 Punch Head Assembly/E

3

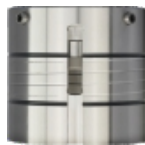

Thick Turret / 85 Fully Guided Guide

4

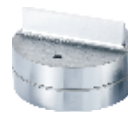

Thick Turret/85 Fully Guided Punch/E

5



Thick Turret/85 Fully Guided Stripper Plate/E

6



Thick Turret Die/E

Description

Size

General use

General use





General use

RE5*110

RE5*110

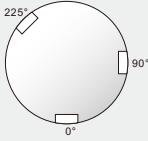
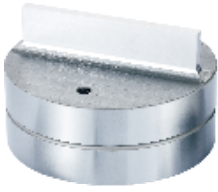
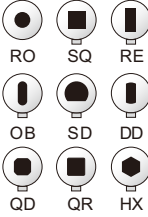
RE5*110+0.15

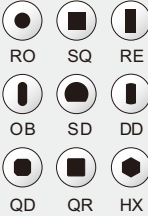
E STATION T85 FULLY GUIDED

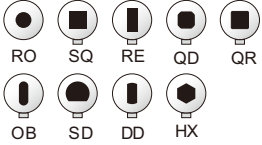
Product		Product Overview
<p>Punch Assembly</p> 	<p>Triple Grooves (0°, 90°, 225°)</p> 	<ul style="list-style-type: none"> • ABS: Air Blow System, oil mist lubrication, anti-scratch, anti-adhesion, longer punch life.
<p>Punch ABS</p> 		<ul style="list-style-type: none"> • Interchangeable: can be installed in others brands guide assemblies. • Using HRC 63 High-Speed Steel for exceptional durability in high-stress environments. • TiCN coating and rooftop shear are available upon request for additional protection.
<p>Stripper Plate ABS</p> 		<ul style="list-style-type: none"> • KETEC 85ABS Stripper Plate
<p>Die</p> 		<ul style="list-style-type: none"> • Standard: Slugfree. • Options: Slughugger, Vacuum. • After grinding, a die shim is required to maintain a consistent height of 30mm. • We offer 0.4mm [0.0157"] / 0.8mm [0.0315"] / 1.2mm [0.0472"] die shims, 5pcs/pack.

Description

1 Guide assembly

2 Punch ABS

3 Die

4 Stripper Plate ABS

5 Die shim

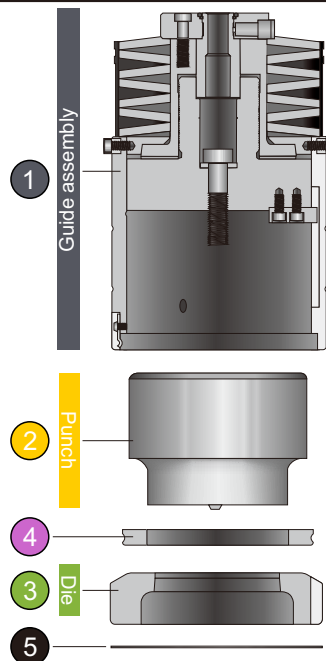
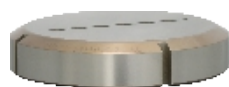

- RO: Round.
- RE: Rectangle.
- SQ: Square.
- ▭ OB: Oblong.
- ▭ DD: Double D.
- SD: Single D.
- QR: Quad R.
- ◆ HX: Hexagon.
- QD: Quad D.

Product	Product Overview	
<p>Punch Assembly</p> 	<p>Double Grooves (0°, 90°)</p> 	<ul style="list-style-type: none"> Parting and slitting are common practices in sheet metal fabrication. Whether you are parting nested parts or straightening the edge of the sheet, you need a Close-to-clamp tool specifically to maximize your productivity for those applications.
<p>Punch</p> 		<ul style="list-style-type: none"> Using HRC 63 High-Speed Steel for exceptional durability in high-stress environments. TICN coating and rooftop shear are available upon request for additional protection. Common sizes: RE5*100, RE8*100, OBØ6*100
<p>Stripper Plate</p> 		<ul style="list-style-type: none"> Close-to-clamp stripper maximizes sheet use
<p>Die</p> 		<ul style="list-style-type: none"> Standard: Slugfree. Options: Slughugger, Vacuum. After grinding, a die shim is required to maintain a consistent height of 30mm. We offer 0.4mm [0.0157"] / 0.8mm [0.0315"] / 1.2mm [0.0472"] die shims, 5pcs/pack.

Description

1 Guide assembly

2 Punch

3 Die

4 Guide

5 Stripper Plate

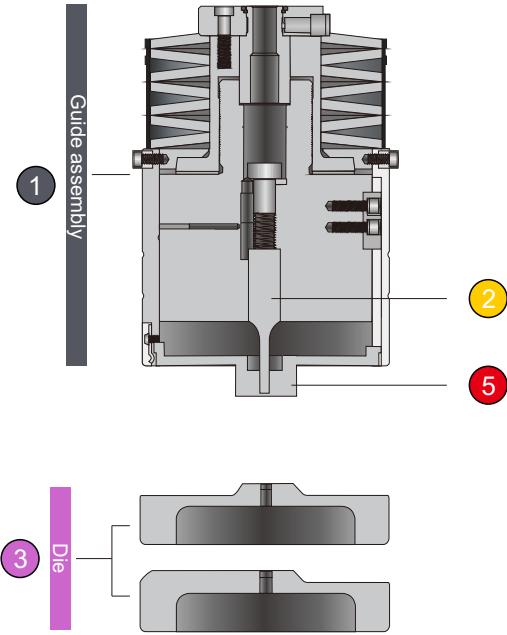

- RO: Round.
- RE: Rectangle.
- SQ: Square.
- ▭ OB: Oblong.
- ▭ DD: Double D.
- SD: Single D.
- QR: Quad R.
- ◆ HX: Hexagon.
- QD: Quad D.